

## Concepts of this Module

- Introducing current and voltage
- Simple circuits
- Circuit diagrams

## Background

When water flows through a garden hose, we can characterize the rate of flow as the volume of water passing any cross section of the hose per time. Units for this flow could be  $\text{m}^3/\text{s}$ . Similarly, for a conducting wire electric charge can flow down the wire. We call the rate of flow of electric charge the *current*, which is the charge  $Q$  passing a cross section of the wire per time  $t$ . In SI units this is  $\text{C/s}$ .  $1 \text{ C/s}$  is also called an *ampere*,  $\text{A}$ . Conventionally the current is given the symbol  $I$  or  $i$ , so the definition of current is:

$$I \equiv \frac{\Delta Q}{\Delta t}$$

In order for water to flow in a hose a source of pressure is required. Similarly, for a current to flow in a wire a source of *voltage* is required. Common voltage sources are batteries, electric generators, and power supplies. In this Module we will be using a battery.

## Record Keeping

The keeping of good records in the laboratory notebook is an important skill for any experimental work. In this Module, some of the data you take may be used in later Modules. So be particularly careful to insure that the notebook contains a complete record of all the Activities you perform.

## The Activities

**Note:** the battery you will be using in the Activities is filled with acid. Do not lay it on its side or turn it upside down.



### Activity 1

Mounted on a plastic frame is a light bulb and two *banana sockets*. On the bottom of the light bulb are two metal contacts which are connected to wires. The

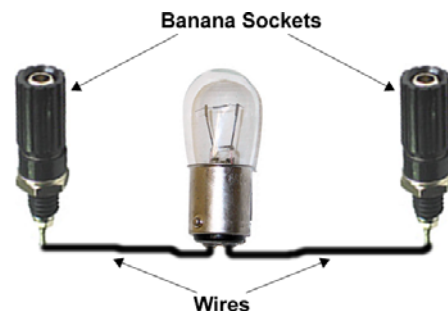

other ends of the wires are connected to the banana sockets, which are a convenient way to attach wires with a corresponding plug. The figure on the previous page shows the bulb, wires and sockets.

The figure to the right traces the conductors from the banana sockets through the light bulb. If you are viewing this in color, the conductors are in red.



- A. Examine the mounted light bulb and identify the parts that are indicated in the above figures. Connect a wire from each terminal of the battery to each of the banana sockets. The light bulb should light. It is good practice to use a red wire to connect to the red terminal of the battery marked +, and a black wire to connect to the black terminal of the battery marked -.
- B. Here are four possible models for how the current flows in the wires when the light bulb is lit:

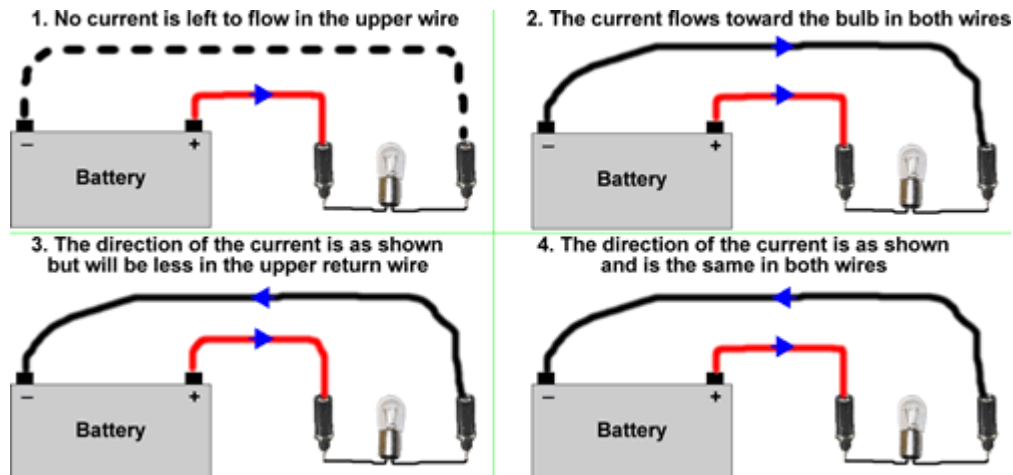

Which case is most correct? Why?





- C. You are supplied with a *clamp meter*, which measures the current in a wire that goes between the jaws of the clamp. Appendix 1 describes how to use this meter. Use the meter to measure the current in one place along one of the wires. As you slightly move the position of the clamp the measured current will change a bit. Quantify this by guessing the error  $\Delta I$  to one significant figure.<sup>1</sup>
- D. Use the clamp meter to check your prediction of Part B. Were you correct?

<sup>1</sup> Although one can carefully repeat the measurements of the current and calculate the standard deviation to get a value for  $\Delta I$ , that will not be necessary here. This is a general principle: do things the simple way first. If you later discover that you need a more careful determination you can always go back and do so.

Please disconnect all the wires and turn off the meter when you are done with this Activity.

## **Expt Activity 2**

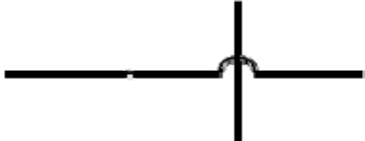
Instead of drawing a picture of an electric circuit, we can schematically represent it with a *circuit diagram*. Here are a few elements of circuit diagrams.

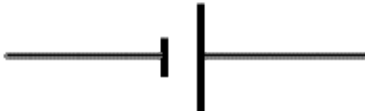
Wire	
Wires that are joined	
Wires that are not joined	
Light Bulb	
Battery	

For the Battery, the positive terminal is on the right and the negative terminal is on the left. Here is a mnemonic for remembering this: a + symbol has more line in it than -, and the longer line of the battery is the + terminal.

Draw a circuit diagram of the circuit of Activity 1.

## **Course Concepts Activity 3**

In Activity 1 the light bulb had two conducting contacts on the bottom. Most light bulbs only have a single contact on the bottom, and use the conducting side of the base for the other contact.

Using the supplied unmounted flashlight light bulb, the battery, and only *one* wire can you make the light bulb light? You may not cut the wire.





## Expt Activity 4

- A. A *knife switch* is just a length of conductor on a pivot and a contact for the conductor. Connect the knife switch as shown *between* one terminal of the battery and one terminal of the mounted light bulb as shown. When the “knife” is closed what happens? Explain why the circuit behaves like this. You will want to notice how bright the light bulb is when the switch is closed.

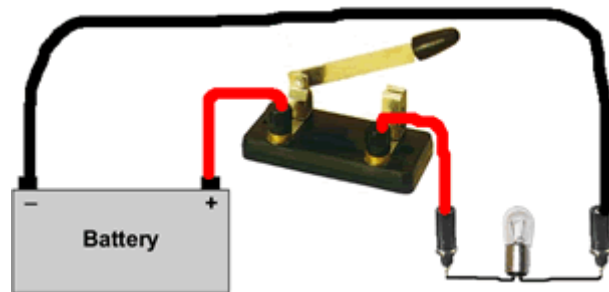

You are supplied with a common light switch which is mounted with banana sockets for easy connection. A photograph of the insides of such a switch appears to the right, and a simple Flash animation of it is at:

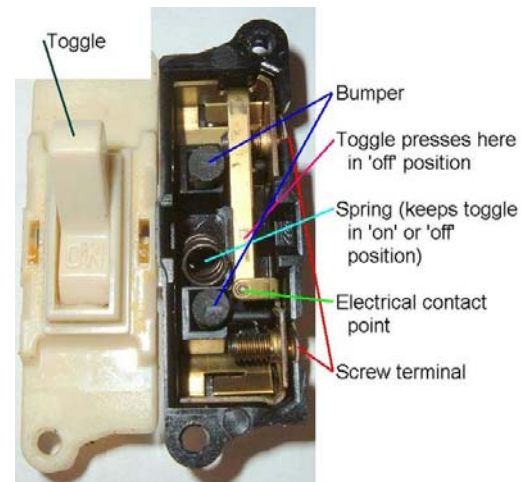

<http://faraday.physics.utoronto.ca/PVB/Harrison/Flash/LightSwitch/LightSwitch.html>.

The above link is to a fixed size animation which works nicely if only one person is viewing it. For use in the Practical itself a version which can be resized to be larger so that the entire Team can see it is better. Here is a link to such a version:

<http://faraday.physics.utoronto.ca/PVB/Harrison/Flash/LightSwitch/LightSwitch.swf>

This version will only work if your browser is configured to display Flash animations directly without an html wrapper.

Explain how this switch works.

- B. Place the light switch in the circuit in place of the knife switch that you used in Part A. Close and open the switch. Is its effect on the circuit and the light bulb any different than the knife switch?

- C. The symbol for a switch, either the knife switch or the light switch, is shown to the right.



So here is the circuit diagram for the circuits of Parts A and B. In the circuit, we say the switch is wired in *series* with the battery and the light bulb. Note that although the components are laid out differently from the figure in Part A, the two representations are completely equivalent.

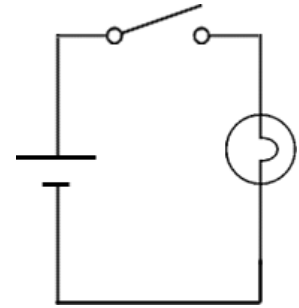

Here is a circuit in which we say the two switches are wired *parallel* to each other. If both switches are closed at the same time *predict* how the brightness of the light bulb will compare to when only one switch is closed. Explain your prediction.

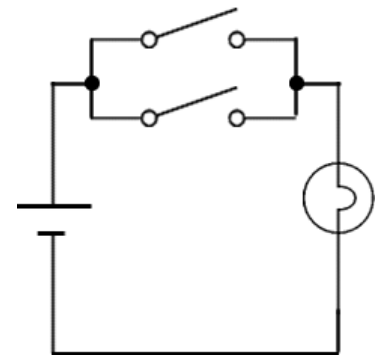

Wire the circuit and check your prediction. You will find it convenient to note that the banana plugs on the ends of the wires have an extra hole into which another banana plug may be inserted.

Please disconnect all wires from all the circuit elements when you have completed this Activity.



## Expt Activity 5

Meters that measure currents are called *ammeters*. Conventional ammeters, as opposed to the clamp meter you used in Activity 1, must be inserted in *series* into the circuit, just as the single switch was inserted into the circuit in Parts A and B of Activity 4. The circuit diagram symbol for a conventional ammeter is shown to the right.

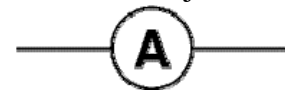

Here is the circuit diagram for using a conventional ammeter to measure the current in a wire of the same setup you investigated in Activity 1.

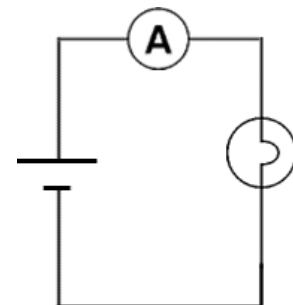

You are supplied with *multimeters* which can be used as conventional ammeters. Details on how to do this are in Appendix 2.A.

Wire the circuit and measure the current in the wire. Check your measurement using the clamp meter. Do they give the same results for the magnitude and direction of the current? How do the values compare to the results of Part D of Activity 1?

Please disconnect all wires from all the circuit elements and turn off the meters when you have completed this Activity.

## Expt Activity 6

*Voltmeters* measure voltages of, say, batteries. The circuit symbol for a voltmeter is shown to the right.



Voltmeters are typically wired in *parallel*. So the circuit diagram that measures the voltage of the battery while the light bulb is being lit is shown to the right.

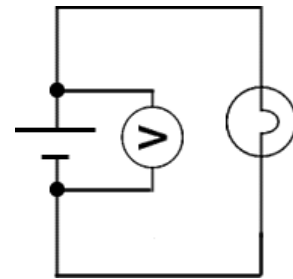

Instructions on how to use a multimeter as a voltmeter are given in Appendix 2.B. Use a multimeter to measure the voltage of the battery. The rated voltage is written on the front of the battery. How do the two values compare?

Disconnect the battery from the circuit and use the voltmeter to measure its voltage. How does it compare with the voltage when it was in the circuit?

Please disconnect all wires from all the circuit elements and turn off the meter when you have completed this Activity.

## Course Concepts Activity 7

Rewire the circuit that lights the 6V 6W light bulb with the ammeter in the circuit again. In the circuit diagram to the right we have indicated a number of points in the circuit. Use the voltmeter to measure the voltage difference between 1 and 2, 2 and 3, 1 and 3, 4 and 5, etc. If the meter reads a very small voltage difference between two points, you should decrease the scale of the reading by rotating the

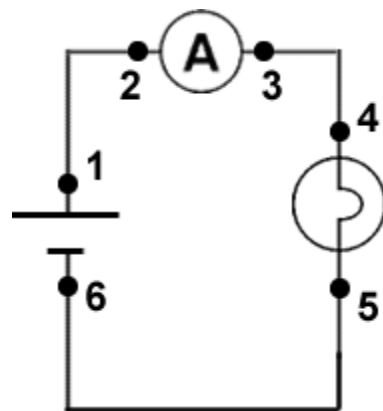

upper knob: when the scale is too small the meter will read **-1**; in this case increase the scale of the reading.

Do you see a pattern? What is the voltage “drop” across the light bulb? What about across the ammeter? One of the wires? Summarise your findings. Can you explain them? Why did we use the word “drop” above?

Please disconnect all wires from all the circuit elements and turn off the meters when you have completed this Activity.

## Appendix 1 – The Clamp Meter

A *clamp meter* measures the current in a wire that passes through the jaws of the circular clamp. For now we will treat how the meter does this as “magic”; in a later Module we will return to investigate how it works.



The jaws may be separated by pressing on the **Clamp Opening Handle**.

When the current is flowing in the direction shown, the reading will be positive; if the current is flowing in the opposite direction to that shown the reading will be negative. There is a small arrow on the inside of the jaws of the clamp indicating the current direction shown in the figure.

Here is a close-up of the controls of the meter. The **Function Select** knob has three positions:

1. **Off**
2. **400A**
3. **40A**

We will be using the **40A** function.

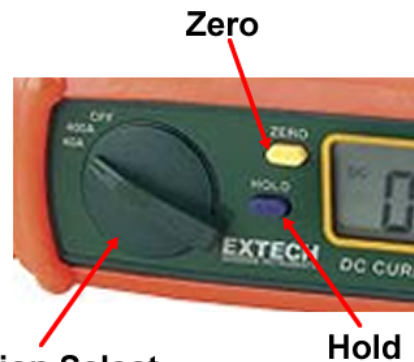

After turning the meter on it must be zeroed.

1. Place the meter close to the part of the wire whose current will be measured and orient the meter as it will be when it is clamped around the wire.
2. Press **ZERO**: The display will read **ZERO**.
3. Press on the **Clamp Opening Handle** to separate the jaws of the clamp, place the clamp around the wire, and release the handle.

The meter will now read the current in the wire in *amperes*.

To measure the current at a different location or with the meter at a different orientation:

1. Move the meter close to where it will do the new measurement, oriented as it will be when clamped around the wire.
2. Press on **ZERO**; the display will no longer read **ZERO**.
3. Press the **ZERO** button again: the display will read **ZERO**.
4. Clamp the meter around the wire and read the current on the display.

If it is difficult to see the display because of the orientation of the meter:

1. Press on the **HOLD** button. This will cause the reading to be held and the display will read **HOLD**.
2. Remove the meter and read the current on the display.
3. Press on the **HOLD** button to return the meter to normal operation. The display will no longer read **HOLD**.

## **Appendix 2 – The Multimeter**

This module uses multimeters, which are devices capable of a number of different electrical measurements. With the flexibility of this instrument comes a price: at first glance there is a bewildering array of controls and inputs. This Appendix will guide you through this complexity to learn how to use the meter to measure DC currents and voltages.

Just as for the clamp meter, for now we will treat how the instrument actually works as “magic”.

**Note:** typically a multimeter is capable of measuring currents and voltages in a number of different ranges. You should always begin measurements with the largest available range. This is because if the voltage or especially the current is much larger than the selected range you can easily blow a fuse inside the meter.

**Note:** particularly for current measurements, turn off the power to the circuit or disconnect the battery before putting the meter in the circuit.

**Note:** please conserve the batteries inside the meter. When you are finished using the meter turn it **OFF**.

**Note:** if the meter starts to beep, something is wrong! Please turn off the meter and the power to the circuit and investigate further.



## 2.A – Measuring DC Currents

The figure below shows the multimeter set up to measure a DC current with a maximum value of 10 amperes.



Note that:

1. The red wire is connected to the **10A** input on the meter.
2. The black wire is connected to the **COM** input on the meter. This is the common input which is paired with the various other inputs depending on what you are trying to measure.
3. The rotary knob points to **40m/10A**. When the red wire is connected to the **10A** input as here, this measures a 10 ampere maximum DC current. The  icon to the right is the symbol used by the meter for DC currents.

If the current flows through the meter from the **10A** input to the **COM** one, the display will be a positive number. If the current is flowing the other way, it will be negative.

**If you are sure** that the current that you wish to measure is less than 300 mA, then you may set up the meter as shown on the next page. If you are not sure, first do a 10A measurement as just described.

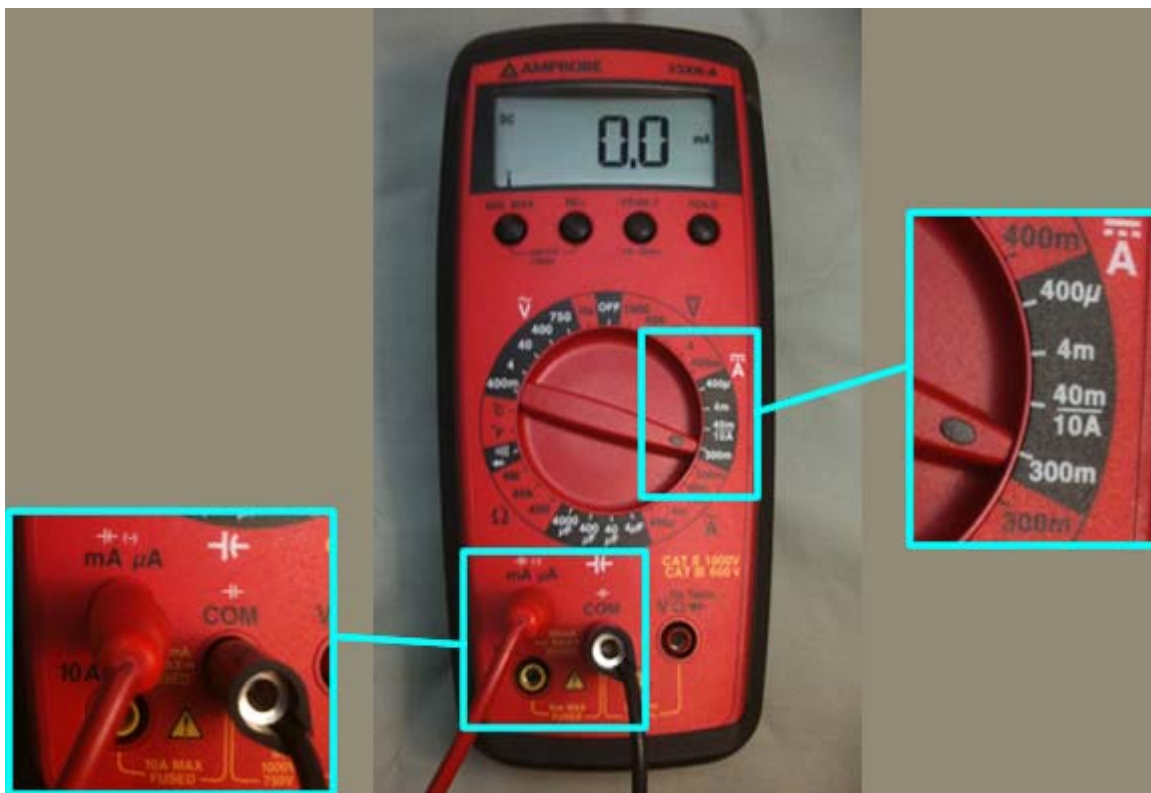

Note that:

1. The red wire is connected to the **mA  $\mu$ A** input on the meter.
2. The black wire is connected to the **COM** input on the meter. This is the common input which is paired with the various other inputs depending on what you are trying to measure.
3. The rotary knob points to **300m**. This selects a maximum current of 300 mA.

You should always begin with the **300m** range selected. If the display reads a current less than 40 mA, you can then select the **40m** range. Similarly, the **4m** range has a maximum of 4 mA, and the **400 $\mu$**  range has a maximum of 400  $\mu$ A.

If the current flows through the meter from the **mA  $\mu$ A** input to the **COM** one, the display will be a positive number. If the current is flowing the other way, it will be negative.

## 2.B – Measuring DC Voltages

The figure on the next page shows how to set up the meter to measure DC voltages.



Note that:

1. The red wire is connected to the **V Ω** input. This input can measure either voltage or resistance. Here we will measure DC voltage.
2. The black wire is connected to the **COM** input. This is the common input which is paired with the various other inputs depending on what you are trying to measure.
3. The rotary knob points to **1000**. This selects a maximum range of 1000 V. The icon shown to the right is the symbol used by the meter to indicate DC voltages, and the **1000** that is selected with the rotary knob in the above figure is in the group of ranges indicated by this symbol.



You should always begin with the **1000** range selected. If the voltage is less than 400 V, you can then turn the rotary knob to the **400** position. Similarly, there are ranges for 40 V, 4 V, and 400 mV.

If the voltage at the **V  $\Omega$**  input is positive relative to the voltage of the **COM** input, the display will be a positive number. If the **V  $\Omega$**  voltage is negative relative the **COM** one, the display will be a negative number.

This Guide Sheet was written by David M. Harrison, Dept. of Physics, Univ. of Toronto in November 2007. Activity 1 draws on material from Priscilla W. Laws et al., **Workshop Activity Guide**, Module 4, Unit 22.6, (John Wiley, 2004), pg. 604.

The photograph of the interior of a light switch is by Scott Erhardt, and placed in the public domain at [http://en.wikipedia.org/wiki/Image:Light\\_switch\\_inside\\_explained.jpg](http://en.wikipedia.org/wiki/Image:Light_switch_inside_explained.jpg).

Revised by David M. Harrison and Lilian Leung. Last revision March 17, 2011.